

passend für
 3x Zylinderkopfschraube
 DIN912/ ISO4762 mit M5
 suitable for
 3x cylinder-head bolts
 DIN912/ ISO4762 with M5

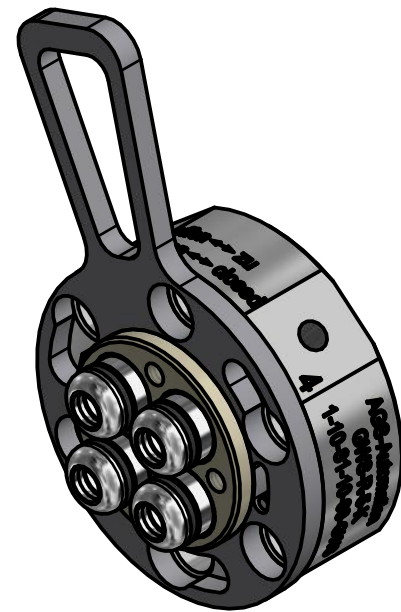
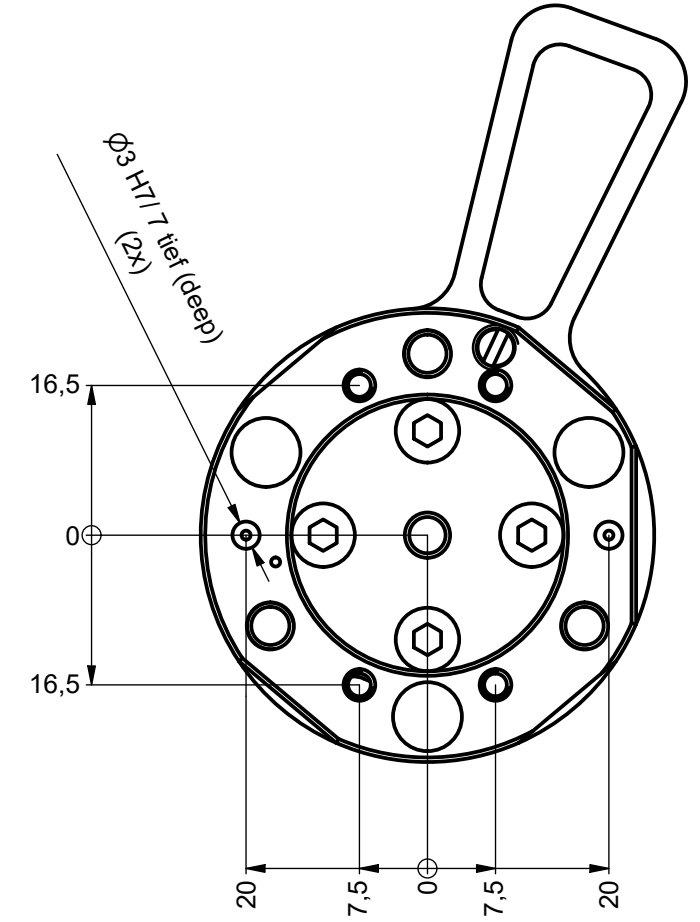
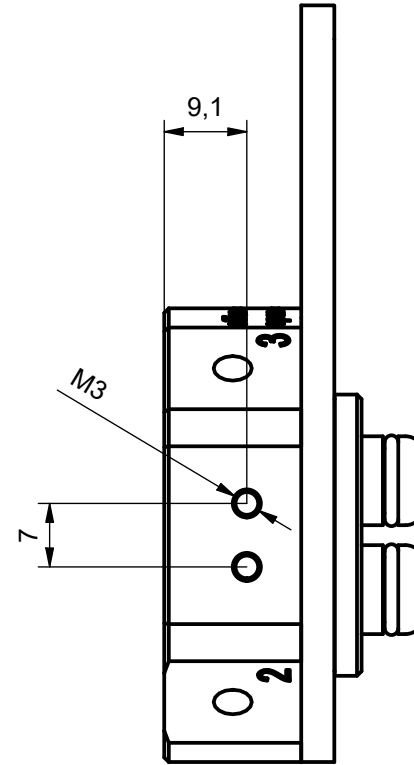
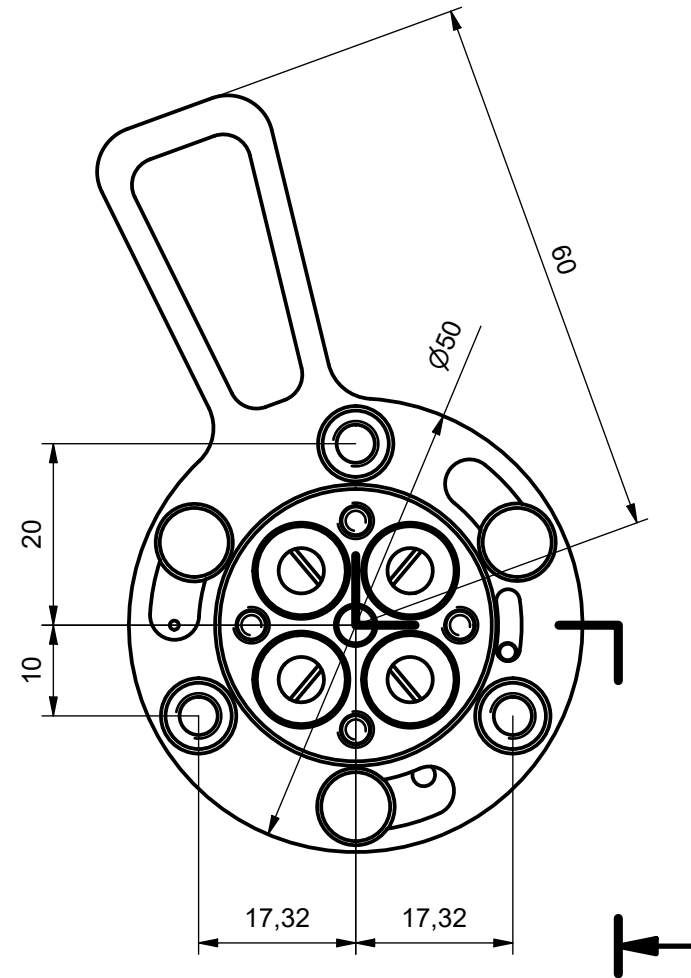
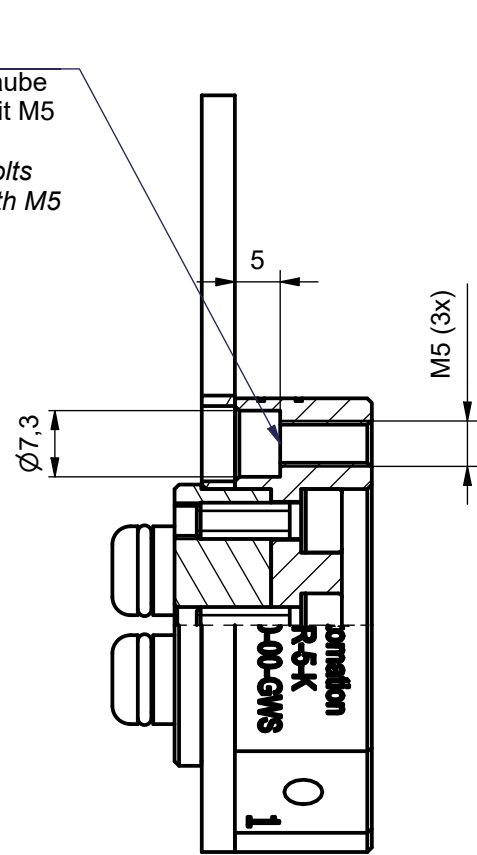

Bei den Belastungswerten handelt es sich um statische Werte:
 max. Handhabungsgewicht 5kg
 max. Drehmoment 30Nm
 max. Biegemoment 15Nm

*Load values are statically determined:
 handling weight only as guidance value 5kg
 (direct at the Quick Change System)
 maximal torque 30Nm
 max. bending moment 15Nm*

Allgemeintoleranz nach DIN ISO 2768-1		Maßstab:		Gewicht: -		
		Werkstoff:		Abmaße:		
		Datum	Name	Greiferwechselsystem GWS-R-5-K EOAT Quick Change System Round - Fixed GWS-R-5-K		
		Gezeichnet	22.12.2015			V.Klug
		Kontrolliert				
		Norm				
		AGS		1-10-81-10-00-GWS		
Status	Änderungen			Datum	Name	1
				A3		
				<PLOTDATE>		